



ECS Fabrications offers a huge array of metal fabrication work, from large structural steel fabrications with individual components anywhere from 100kg to 40 tonnes.

Our 50,000 sq ft fabrication site in the North Midlands also includes our own steel stockyard and logistics solutions. All our metal fabrication work has CE Marking approval to EXC3 and our well equipped and highly skilled engineers can complete structural steelwork, bespoke fabrication work and access metalwork to the highest standard.

Grab Bucket

Case Study: 006 Grab Bucket

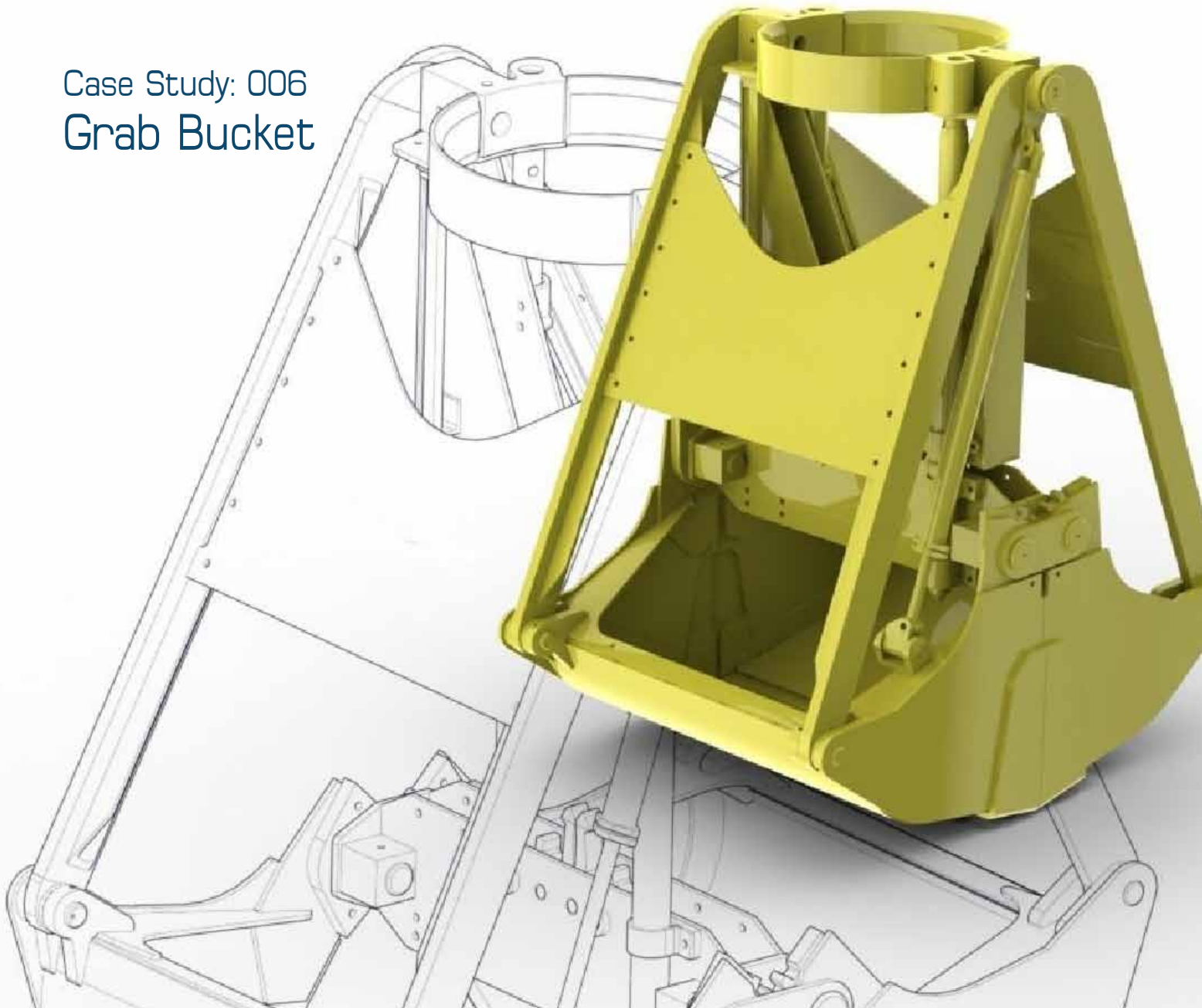

ECS Engineering Services was commissioned to translate aged imperial dimensioned drawings for a legacy design of a complicated, automatically operating, grab bucket.

From this initial translation a working 3D model was created and analysed within the computer to adjust the design to suit modern material sizes,

while retaining the original fit and functionality of the interconnecting parts

ECS then fabricated the bucket using modern manufacturing methods (such as laser cutting) for the majority of the parts and assembled the completed fabrication, which stood over 2.5 metres high within our workshop.

The operation of the bucket was then demonstrated to the satisfaction of the client using our overhead crane to test and operate the mechanism.



Engineering Services ■■

Water Control ■■ Site Services ■■
Environmental ■■ Fabrications ■■